



Office of Utility Regulation

# **Licensing of Internet Access in the Bailiwick of Guernsey**

---

Consultation Document

**Document No:** OUR 03/27

**September 2003**

**Office of Utility Regulation**  
Suites B1 & B2, Hirzel Court, St Peter Port, Guernsey, GY1 2NH  
Tel: (0)1481 711120, Fax: (0)1481 711140, Web: [www.regutil.gg](http://www.regutil.gg)

## Contents

1.	Introduction.....	2
2.	Structure of the Paper.....	3
3.	Background.....	4
3.1.	History of licensing in Guernsey .....	4
3.2.	Legislative Background .....	5
3.3.	Scope of Licensing.....	5
3.4.	ISP Licensing .....	6
4.	Provision of ISP Services.....	7
4.1.	Dial up access to the Internet .....	7
4.2.	Accessing the Internet using Leased Lines.....	9
4.3.	Accessing the Internet using DSL.....	10
4.4.	Conclusion .....	11
5.	Exemption of Internet Access from Licensing .....	12
5.1.	Licensing Options .....	12
5.2.	Exemption of ISPs .....	12
5.3.	Public Interest .....	13
5.4.	Public Safety .....	13
5.5.	Economic reasons .....	13
5.6.	Market Entry .....	14
5.7.	Conclusion .....	14
6.	Separate Licensing of Internet Access.....	15
6.1.	International Developments .....	15
6.2.	Market Entry .....	16
6.3.	Definition and Policing.....	17
6.4.	Conclusion .....	18
7.	Rights, Entitlements and Obligations in Licences .....	20
7.1.	Obligations in the Licence .....	20
7.2.	Interconnection and Access .....	20
7.3.	Non-Discrimination .....	20
7.4.	Conclusion .....	21
8.	Proposed Adjustment of Existing Licencing Regime.....	22
8.1.	Existing Licence Conditions .....	22
	Annex 1: List of Questions .....	24
	Annex 2: Telecommunications Licence – Explanatory Note on Conditions ..	26

# 1. Introduction

All parts of the telecommunications market in the Bailiwick of Guernsey have been fully open to competition since April 2003. However, competition in the provision of internet services has been in existence for considerably longer than that with a number of Internet Service Providers (ISPs) holding licences issued by Guernsey Telecom (GT), the States Telecommunications Board, for several years before the gradual liberalisation of the market started in 2002.

Since the introduction of new legislation in 2001, the licensing of all telecommunications activities has been the responsibility of the Office of Utility Regulation (OUR) and, in keeping with the OUR's stated policy of regulating only where necessary, not all service providers previously licensed are now required to hold a telecoms license.

The existing licensing regime in Guernsey is based on one set of comprehensive conditions. Which conditions apply to each licensee depends on the activities of the licensee in the market and various other factors such as whether the licensee has been found to have a dominant position in a relevant market or has a universal service obligation. As telecommunications markets have developed internationally, there has been increasing use of "class licences" or "authorisations" which follow a similar pattern, i.e. there is one central set of conditions and the conditions apply to each operator are determined by the activities the operator is engaged in.

The key difference between the Guernsey regime and the use of authorisations, is that in the case of the latter, the operator does not have to apply for and receive an explicit licence in its own name, but can simply self police its activities in accordance with the published conditions. The Director General (DG) has received representations to consider a move towards using the "authorisation" or "class licence" model in Guernsey, particularly in relation to those ISPs whose activities are restricted to what is commonly understood as the provision of internet access to end users.

This consultation paper revisits the existing licensing regime in Guernsey and describes the provision of internet access within the context of that regime. It describes the legal licensing requirements for such activities and goes on to consider whether ISPs should be either exempt from the requirement to hold a licence, or subject to a separate licensing regime to other types of operators.

The paper concludes that the existing licensing regime applies to ISPs and suggests that a new licensing category could create confusion and add cost to the regulatory regime. However, the DG does consider that it may be appropriate to make some adjustments to the existing regime to remove some of the obligations in the regime from some of the smaller operators.

*This document does not constitute legal, technical or commercial advice; the DG is not bound by this document and may amend it from time to time. This document is without prejudice to the legal position or the rights and duties of the DG to regulate the market generally.*

## 2. Structure of the Paper

This paper is structured as follows:

- Section 2 sets out the structure of this consultation paper, the details of the consultation period and how to respond to the consultation;
- Section 3 summaries the development of the licensing regime in Guernsey to date and the legal background to the licensing regime;
- Section 4 describes those ISP activities that the DG understands are considered by some interested parties as possibly appropriate for licensing by class licence;
- Section 5 considers whether ISPs should be exempt from the requirement to hold licences;
- Section 6 describes the benefits and drawbacks of a separate licensing regime for ISPs and provides some background on international trends;
- Section 7 outlines how the existing regime provides for appropriate rights, entitlements and obligations for all operators and ISPs in particular;
- Section 8 concludes the paper and proposes some adjustments to the existing licensing regime;
- Annex 1 provides a summary list of all of the questions in this consultation paper; and
- Annex 2 contains a list of all conditions currently in the fixed telecommunications licence.

The consultation period will run from 10<sup>th</sup> September to Friday 3<sup>rd</sup> October, 2003. Written comments should be submitted before 5.00pm on 3<sup>rd</sup> October, 2003 to:

Office of Utility Regulation,  
Suite B1 & B2,  
Hirzel Court,  
St. Peter Port,  
Guernsey GY1 2NH.

Email: [info@regutil.gg](mailto:info@regutil.gg)

All comments should be clearly marked “Comments on the Licensing of Internet Access in the Bailiwick of Guernsey”.

In line with the policy set out in Document OUR 01/01 – “Regulation in Guernsey; the OUR Approach and Consultation Procedures”, the Director General intends to make responses to the consultation available for inspection. Any material that is confidential should be put in a separate Annex and clearly marked so that it can be kept confidential.

The Director General regrets that she is not in a position to respond individually to the responses to this consultation, but she proposes to issue a response to the consultation in October 2003.

## 3. Background

### 3.1. *History of licensing in Guernsey*

Prior to the establishment of the OUR and the introduction of the current licensing regime, the regulation and enforcement of States policy in relation to the telecoms market was undertaken by the States of Guernsey Telecommunications Board – in effect GT as it was then. GT issued licences for the provision of certain telecommunications services including ISP and simple resale services.

With the establishment of the OUR and the introduction of the Telecommunications (Bailiwick of Guernsey) Law 2001 (“the Telecoms Law”) and the Regulation of Utilities (Bailiwick of Guernsey) Law 2001 (“the Regulation Law”), the licensing of telecoms services fell to the DG of the OUR. In August 2001, the DG consulted on the scope of the services that would fall to be licensed under the new regime and on the form of the licences – including the rights and obligations of any operator holding a licence<sup>1</sup>. Following the consultation the DG finalised the licence texts<sup>2</sup> and the scope of services to which they would apply<sup>3</sup>. In that context, guidance was given on what telecommunications services would not require to be licensed, although in line with the Law, the DG reserved the right to carry out a case-by-case examination of any specific activity to determine if it fell to be licensed.

In October 2001, the DG licensed GT as the first licensee to provide both fixed and mobile telecommunications networks and services within, to and from the Bailiwick. With the scheduled opening of the market to competition in July 2002, further fixed licences were awarded to Wave Telecom Ltd and Newtel Guernsey Ltd in November 2002. In April 2003 Wave Telecom was awarded mobile licences to provide both 2G and 3G mobile networks and services. A number of ISPs that had previously been licensed under old regime were allowed to continue to operate under their previous licences.

The existing licensing regime in Guernsey is based on a single modular licence that applies to all operators providing licensed telecommunication networks and services to the public in the Bailiwick. The fixed telecoms licence terms and conditions are published on the OUR website and are organised in “modules”; that is all the conditions considered necessary for a full telecommunications operator licensee are in the licence. However, certain groups of obligations and rights only become applicable as an operator either is found to have a dominant position in the market, or where the operator enters a certain market, e.g. payphones. Likewise, as competition increases it is intended that certain obligations maybe removed if they are considered no longer appropriate.

This regime, developed following public consultation, follows the general international trends of technology-neutrality and simplicity by avoiding many

---

<sup>1</sup> Document OUR 01/02: Telecommunications in Guernsey; Licensing Framework for a Competitive Market – Consultation Paper

<sup>2</sup> Document OUR 01/18: Fixed Telecommunications Licence Conditions, and Document OUR 01/19: Mobile Telecommunications Licence Conditions

<sup>3</sup> Document OUR 01/12: Telecommunications in Guernsey: Licensing Framework for a Competitive Market – Report on the Consultation Paper

multiple licences for different activities. The DG is now consulting on whether there should be changes to that regime, specifically whether there is a requirement or a benefit to be gained from a specific class licence for ISP activities.

### **3.2. Legislative Background**

The Regulation Law and the Telecoms Law together set out the framework within which the licensing of operators to provide telecommunications services and networks in the Bailiwick takes place. This regime was considered in some detail in the consultations during 2001 and the legislation itself is available from the OUR website for reference<sup>4</sup>.

In brief, the relevant activities that fall to be licensed under the Telecoms Law include only those telecommunications services and networks that are provided to the public, specifically:

- The provision of telecommunications services to third parties, and
- The establishment, operation or maintenance of telecommunications networks that are used for the purpose of providing services to third parties or that are themselves provided to third parties for the provision of telecommunications services.

Therefore those services not covered by these definitions are by default not subject to licensing. By way of example this would include any call centre engaged only in providing telemarketing operations on an agency basis – this is considered to be limited to a specific entity and does not include provision of service to the public. Furthermore, a simple audiotext service where access is provided using a third party premium rate service (e.g. Weatherdial) would not fall within the regime where the service provider is providing an information service only and not a telecommunications service

### **3.3. Scope of Licensing**

In considering whether other services or networks should fall to be licensed or should be exempted, the DG concluded that she would consider the following criteria as well as the legal position when addressing this question;

1. Is there a public interest concern that would require the licensing of the activity or service?
2. Are there public safety issues involved?
3. Are there economic reasons for using licensing controls?
4. Is there the prospect of competitive provision of the service or activity in the near future that would be enhanced or encouraged where entry into the market was simple and inexpensive?

On that basis the DG provided some guidance on those services that are considered not to require licensing, although this is without prejudice to the exercise of the DG's statutory function in considering each situation on a case-by-case basis. These include:

- Receive only VSAT (Very Small Aperture Terminals);

---

<sup>4</sup> [http://www.regutil.gg/gen\\_primary\\_legislation.asp](http://www.regutil.gg/gen_primary_legislation.asp)

- The installation, operation and maintenance of customer premises equipment (CPE);
- The installation of internal wiring and equipment; and
- The provision of ISP services covering such services as portal services, a gateway, or other content services such as information services where the ISP is not engaged in the provision of telecommunications services as defined in the Law.

The DG also provided guidance in previous reports on what types of services and networks do require licensing under the Guernsey regime. These include:

- Service providers offering fixed telecommunications services to third parties but not requiring access to numbers and not intending to build networks so not requiring access to land or frequency spectrum;
- Operators proposing to build fixed telecommunications networks and provide telecommunications services and potentially requiring access to land and frequency spectrum;
- Operators with dominance in a relevant market in Guernsey;
- Operators with a Universal Service Obligation (initially Guernsey Telecoms, now C&W Guernsey);
- Operators providing mobile telecommunications services in Guernsey but not requiring access to numbers and not intending to build networks so not requiring access to land or frequency spectrum; and
- Operators providing mobile telecommunications networks and services requiring access to numbers, land or spectrum.

### **3.4. *ISP Licensing***

Within this framework, the DG has received a number of queries and representations specifically relating to the provision of ISP services, the provision of access to internet services and the provision of access to the internet, in particular the services provided directly by ISPs to end users. Also relevant to this issue is the recent introduction of alternative means of internet access such as DSL technology.

This consultation reviews the legal position in relation to licensing of ISPs, sets out where it currently falls within the licensing regime, and considers whether there should be any change to the licensing regime to address ISPs specifically.

## 4. Provision of ISP Services

The focus of this paper is the provision of internet services and the provision of access to the internet by those ISPs that do not own or operate their own network but rather use the existing networks of Other Licensed Operators (OLOs) to enable their customers to access the internet and ISP services.

Figure 1 below illustrates how some of this terminology is used in this document and may assist respondents in framing their replies.

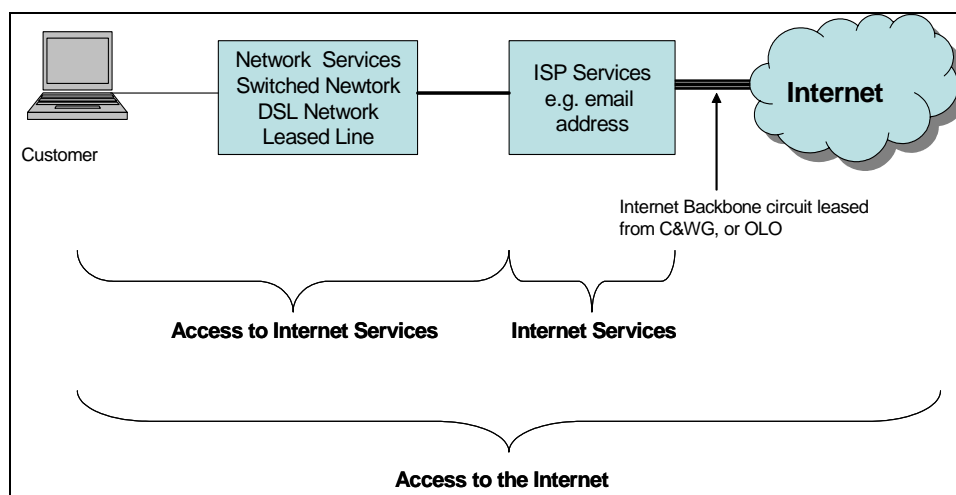

Figure 1

In brief these terms are used as follows:

- the term “provision of internet services” is used to describe the services provided by an ISP that do not involve the conveyance, transmission or emission of messages over a telecommunications network, e.g. assigning email addresses or hosting web space;
- the term “access to internet services” describes the conveyance of messages (in the form of IP packets) from the customer site or equipment, to the ISP; and
- the term “access to the internet” is used to describe the combination of the above two services with the onward conveyance and transmission of messages (in the form of IP packages) to and from the Internet.

The remainder of this section briefly describes of a number of the current ways in which customers access the internet using the services of an ISP. It describes the differentiation between the provision of licensable services and the provision of internet services that are not licensable by describing in each case, which entity is providing services and to whom.

### 4.1. *Dial up access to the Internet*

Using a dial up modem is still one of the most common means for end users to access the internet. As far as the customer is concerned they simply make the equivalent of a normal phone call on their modem and they pay their normal telecoms provider a call charge for the use of the line. The customer may pay his ISP directly for services or the ISP may receive a portion of the call charge paid. This paper is concerned with



the underlying network activities and not the charging or commercial arrangements at this stage. Figure 2 illustrates one form of underlying structure that might be used to provide dial up internet access.

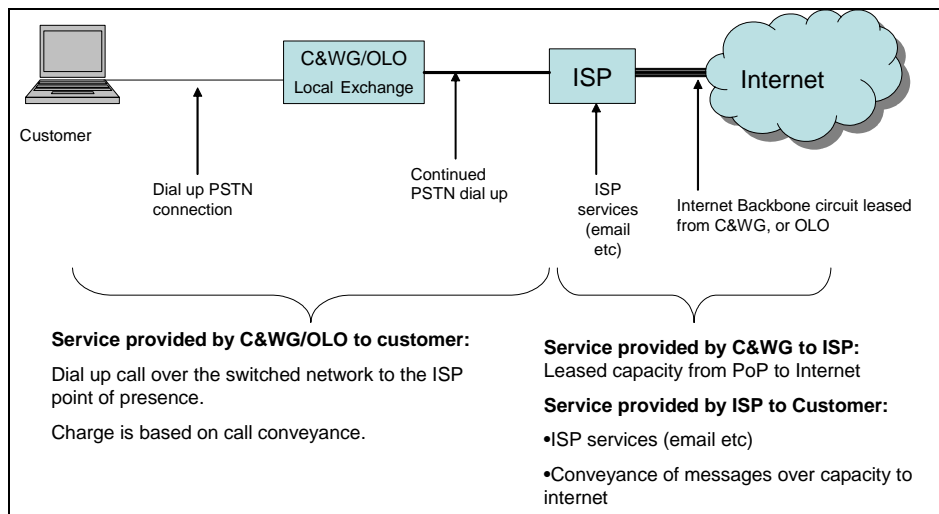
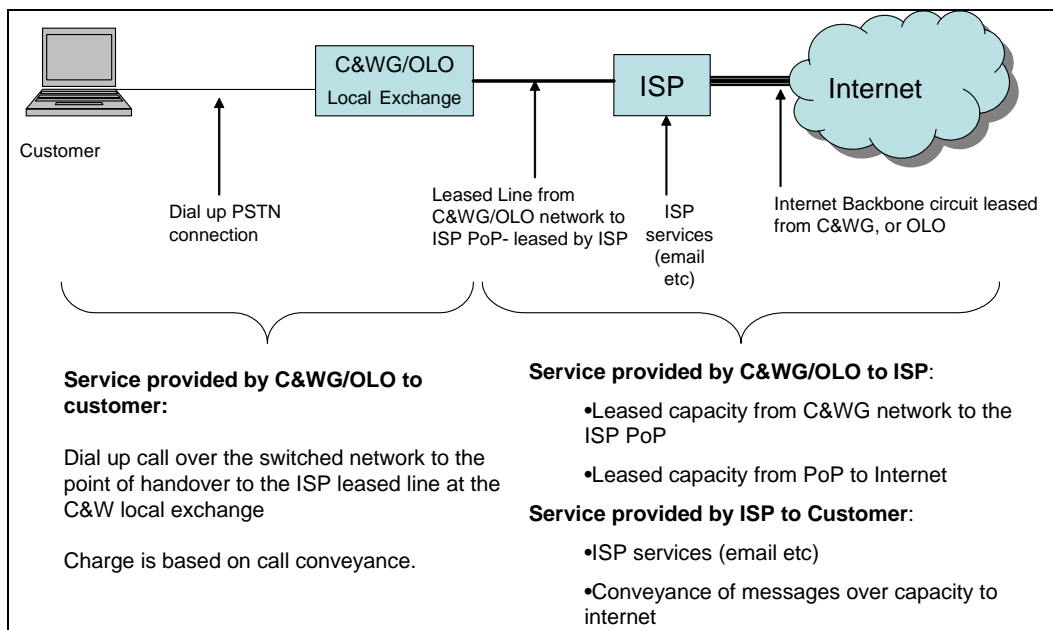

**Figure 2: Dial up Access to the Internet**

In this case, the customer contracts with his/her telecoms provider for normal dial up services. The customer pays the published call charge and in return the telco provides a call service over the normal switched network to the ISP PoP.

In turn the ISP purchases dedicated leased capacity (an Internet Backbone Service or IBS) from a network operator. The ISP then sells to the customer an “internet access” service comprising value added services such as email addresses, webspace etc, along with the conveyance of the customer’s data to and from the internet.

Figure 3 below illustrates a variation on this mechanism:



**Figure 3: Dial up Access to the Internet**

In the case illustrated in Figure 3, the customer receives precisely the same service, but that part of the service provided over the normal switched network is somewhat less, because the ISP connects to the switched network via a leased line, or dedicated capacity.

In both of these cases the ISP is providing a service to the customer that consists of “the emission, transmission, switching, conveyance or reception of messages within, to or from the Bailiwick by means of a telecommunications network”<sup>5</sup> insofar as the ISP is responsible for the conveyance of messages over the IBS. As a result this aspect of the ISP’s activities falls to be licensed under the definitions in the laws.

## 4.2. Accessing the Internet using Leased Lines

Where a larger user has a significant amount of traffic, it may be cost effective for that user to purchase a leased line from the network provider directly between the customer premises and the ISP PoP. This provides the customer with its own dedicated link to its ISP and it does not have to share the capacity with any other customers.

This approach is more likely to be adopted by larger corporate users. In this case the customer pays the network provider for the leased line service and the service purchased from the ISP is identical to that in the dial up scenario – making the licensing position identical also. This is demonstrated in Figure 4 below:

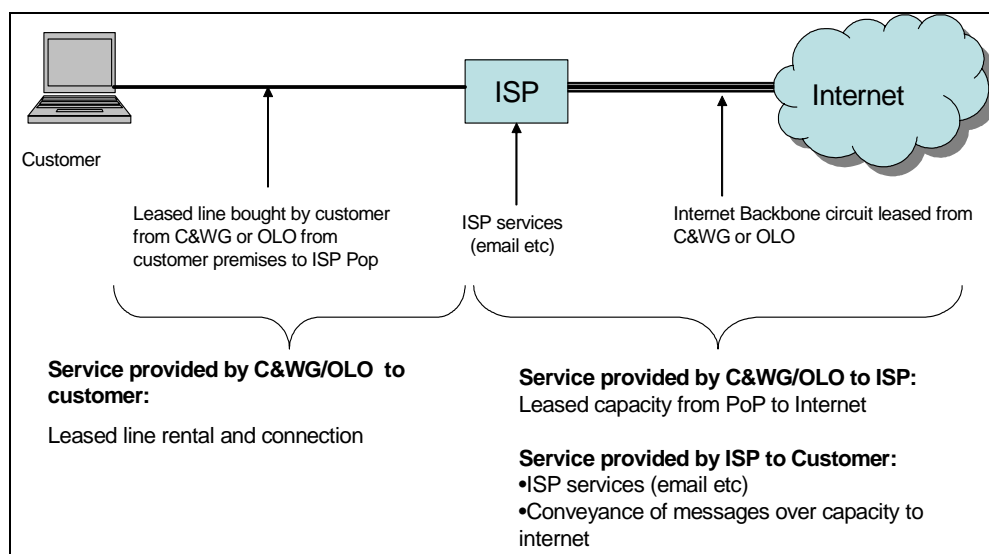
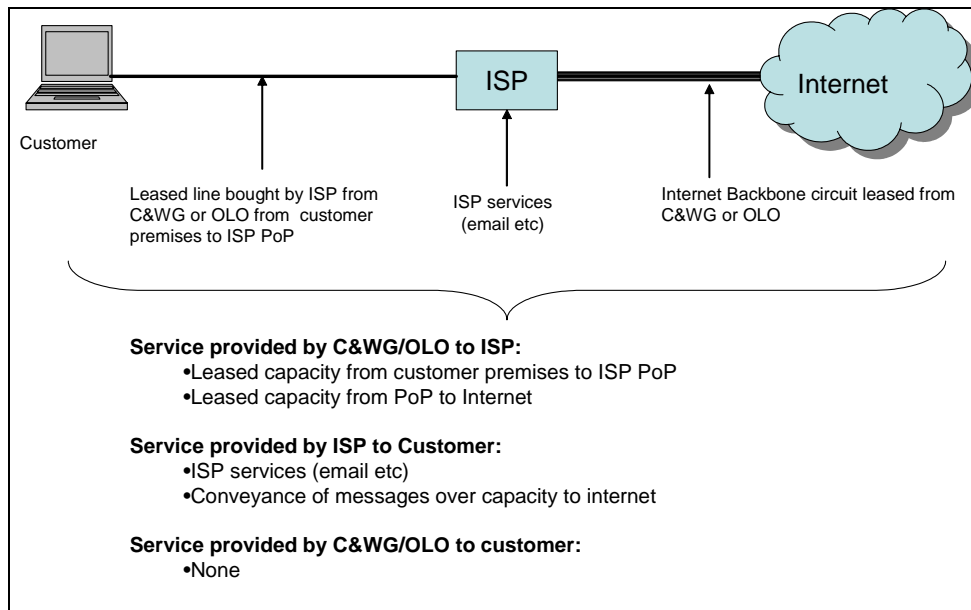

Figure 4: Leased Line dedicated Internet access

In a variation on this, the ISP could lease the circuit between the ISP PoP and the customer premises, and bundle this with the rest of the service the ISP provides and sell a total solution to the end user, adding value through management and other services. This is illustrated in Figure 5:

<sup>5</sup> See the definition of “telecommunications service” in section 31 of the Telecoms Law

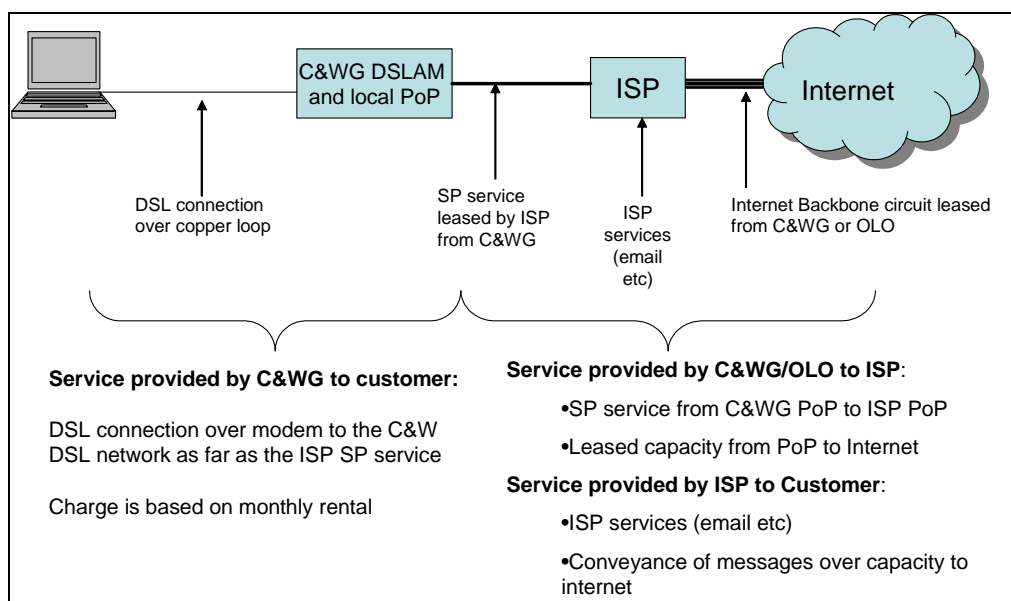

**Figure 5: Leased Line dedicated internet access purchased from an ISP**

It is clear from the above scenario, that ISPs are free to enter into more and more of the value chain, purchasing network access and services and bundling these with value added services to be sold on directly to customers.

### 4.3. Accessing the Internet using DSL

In Guernsey, C&WG has launched a DSL service which has been rolled out throughout the Bailiwick. There are various characteristics of this service that differentiate it from the other types of access, but this paper is primarily concerned with the network arrangements and licensable activities that underpin the provision of the service. Figure 6 shows how the ISP once again purchases certain network services and elements from the network provider and then bundles these for resale along with their own services to end users. The end user may also purchase some services (the DSL access service) from the network provider.



**Figure 6: DSL (Broadband) access to the Internet**

#### **4.4. Conclusion**

In conclusion, as already stated by the DG in Document OUR 01/12, the provision of the pure internet services that ISPs are involved in, such as the assignment of e-mail addresses, the allocation of web space, etc, do not comprise licensable services for the purpose of the legislation. However, those ISPs who are engaged in the provision to third parties of telecommunications services that comprise the conveyance of traffic over telecommunications networks that they lease from another licensed operator, are carrying out licensable activities.

The Director General believes that the majority of ISPs in the Bailiwick fall into this category.

***Q.4.1 Do you agree that the above scenarios accurately describe the services provided by ISPs in Guernsey?***

***Q.4.2 If not, please explain your reasons and your alternative descriptions of ISP activities. Diagrammatic representation of your description would be very welcome.***

## **5. Exemption of Internet Access from Licensing**

### **5.1. Licensing Options**

From the descriptions given in Section 4 of this paper, it is clear that where an ISP leases capacity from a network operator and provides telecommunications services (as defined in the law) over that capacity, then the activities of the ISP fall to be licensed under the Guernsey legislation.

The DG has three options available to her in relation to licensing such activities;

- She can exempt the particular service from a requirement to hold a licence – such exemptions can be made with or without conditions;
- She can issue a “class licence” which includes specific conditions – under this option, all ISPs meeting the conditions could operate without an individual licence in the company’s own name, subject to registering with the OUR; or
- She can issue individual licences – in this case each ISP receives an individual licence with terms and conditions in the licence.

This section of the paper considers whether, in the first instance, ISPs should be exempt from the requirement to hold a licence. This question is assessed against the criteria set out in section 3.3., the technical configuration described in section 4 and the existing Laws.

### **5.2. Exemption of ISPs**

In the spirit of light handed regulation, the first issue to consider is whether the provision of ISP services of the kind described in this paper should be subject to any licence conditions at all. The Director General has set out some high level criteria that she will consider<sup>6</sup> and this question is considered under each of those criteria.

It should be borne in mind that the service that is being considered is the provision to third parties of “telecommunications services” as defined, involving the emission, transmission, reception etc of messages as described in section 4 of this paper. This does not include the provision of value added ISP services such as the assigning of e-mail addresses.

It is also particularly important to consider the range and scope of services that an ISP carrying out any of the activities described in section 4 of this paper could provide, in the context of the existing services and networks that are provided in the Bailiwick of Guernsey. In the current technological climate where there are increasing moves towards the convergence of voice and data as well as broadcast material, it would appear that, with the right technological investment, any such ISP could in fact provide much more than what is traditionally known as internet access services.

For example using this mechanism, an ISP could provide a wide range of telecommunications services over IP directly to the end user, including advanced data services such as media streaming, including films/music or other entertainment, and also core telecommunications services such as fax and voice. In effect the ISP could

---

<sup>6</sup> See Document OUR 02/12:Telecommunications in Guernsey: Licensing Framework for a Competitive Market – Report on the Consultation Paper

provide a full telecoms service, replacing for subscribers the telecoms service they currently receive from the licensed Universal Service Obligation (USO) operator (C&WG), with the exception of the direct provision of physical connection to a network.

### **5.3. Public Interest**

The first issue is whether there is a public interest concern that would require the licensing of the activity or service and the associated imposition of conditions. To consider this, it is useful to look at the corollary of the situation of no conditions. If all ISP activities described in this paper were to be allowed to take place with no conditions then any party could purchase any network element from the incumbent or another operator and provide IP services over that infrastructure, including services to, from and within the Bailiwick without the following controls:

- Customer care requirements;
- Reporting requirements on traffic/network development;
- Any obligation to contribute to the cost of a USO if such a cost were to be identified and considered appropriate to be recouped from licensees;
- Conditions that ensure the continuity of the service, i.e. avoiding the situation where a customer's service provider ceases service provision unexpectedly; and
- Any form of redress where service difficulties arise.

The DG does not consider this is appropriate given the potential to provide a full substitute telecoms service. Where this was the case, the customers subscribing to that service would not be protected in any way by the telecoms licensing regime in that there would be no quality of service obligations, customer care obligations, continuity of service provisions or guarantee of redress should there be service difficulties.

Therefore, the DG concludes that the relevant services should be subject to conditions protecting the interest of customers.

### **5.4. Public Safety**

With regard to public safety, the argument set out above demonstrates how, given technological convergence, ISPs could provide a full substitute telecoms service. Therefore it would appear that the provision of that service should be subject to the same public safety provisions that apply to all other telecommunications service providers.

### **5.5. Economic reasons**

In considering this criterion, the fact that an ISP could provide a full substitute telecommunications service, including services within the USO, would appear to indicate that the provision of such services should not be differentiated from any other telecoms service provider. In particular the issue of rights and entitlements to interconnection and access services are governed by the licensing regime and the law, and it would seem that ISPs should be subject to those rules in order to ensure a level playing field between technologies.

The Director General therefore concludes that ISPs should be subject to conditions in this respect.

## **5.6. Market Entry**

One issue that is worth considering is whether by removing the requirement for licensing, effective competition would be fostered due to the fact that there is no regulatory barrier to entry, no requirement to apply for a licence and no conditions to comply with. This for example is the case in the provision of customer premises equipment.

However, the DG believes that the fact that the ISPs described in section 4 above can potentially provide a full range of telecoms services over IP warrants the imposition of conditions on such operators. Furthermore, the overhead of applying for a licence in Guernsey is low, with an application cost of £2,500. Furthermore, the annual licence fees are set in relation to the turnover of an organisation. Licensees with a turnover of less than £150,000 pay a flat fee of £500 per annum. Licensees with a turnover over this level pay a fee of 1% of turnover (further details of the licence fees are set out in OUR 02/39). Overall therefore the DG does not believe that the current licensing regime acts as a barrier to entry for those ISPs wishing to provide internet access services.

## **5.7. Conclusion**

In conclusion, the DG considers that as a matter of fact, ISPs engaged in the conveyance of traffic can, due to technological advances, potentially provide a full telecommunications service in direct competition with the existing licensees and therefore it is appropriate that they be subject to licence conditions in such cases. Furthermore, where this is possible, the DG considers that the conditions should be the same as those for other similar telecoms licensees. Section 8 of this paper considers further the question of disapplying certain conditions for specific licensees.

- Q.5.1** *Do you agree that the provision of internet access should not be exempted from the requirement to hold a licence?*
- Q.5.2** *If you do not agree please explain your reasons and illustrate how the exemption of the provision of internet access services would create benefits?*
- Q.5.3** *If you consider that the provision of internet access should be exempt from licensing, please set out clearly your definition of what services should be exempt and whether (and if so which) any conditions should attach to the exemption.*

## **6. Separate Licensing of Internet Access**

The differentiation of certain types of activity and the licensing of those activities under separate rules is a characteristic of many licensing regimes throughout the world including Guernsey, where there are specific conditions attached to mobile licences that are different to those in the fixed licences.

However, there has been a general move towards the convergence of licensing because of the convergence of technologies and the increasing substitutability of different types of services, e.g. IP voice for normal switched voice. This characteristic has been part of the Guernsey regime since its inception as the regime has adopted a forward looking approach and incorporated best international practice. Furthermore it ensures a simple, consistent licensing regime in the Bailiwick, thus reducing the regulatory overhead generally as companies do not have to contend with considering multiple licences and the OUR has one consistent set of licence conditions to police and apply.

However, another characteristic of licensing regimes has been the move away from individual licences to “class” licences or “authorisations” which are designed to have less onerous conditions and permit more ease of market entry and exit because of the absence of the need to apply for a specific licence. This is appropriate and workable particularly where effective competition has developed or the prospect of effective competition is close. In such cases, market forces can be expected to protect the interests of consumers.

In the case of Guernsey, the DG is concerned to balance any benefits of a separate licensing regime for ISPs against the cost (in terms of regulatory burden and enforcement) of such a separated licensing regime. This section requests views on whether there are benefits to be gained from this type of differentiation that may outweigh the costs and goes on to consider the practical and implementation issues of such a regime.

### **6.1. International Developments**

The perceived benefits of a separate “class” licensing regimes or “authorisations” in the new EU regime include, inter alia, the simplification of licensing regimes where there are already a multitude of different licences in place, and the reduction of the burden of market entry, thus facilitating competition. The new regulatory regime in Europe has specific provisions requiring a move away from individual licensing to authorisations (through the new Authorisation Directive<sup>7</sup>).

In the UK (which is subject to the new EU regulatory regime) this change is reflected by the fact that the licensing regime has now been replaced by a general authorisation regime. There now exists a general authorisation, called “the General Conditions of Entitlement”, with conditions which apply to all operators, and also some specific conditions that may be applied to individually licensed operators.

---

<sup>7</sup> [http://europa.eu.int/information\\_society/topics/telecoms/regulatory/new\\_rf/documents/l\\_10820020424en00210032.pdf](http://europa.eu.int/information_society/topics/telecoms/regulatory/new_rf/documents/l_10820020424en00210032.pdf)



A key advantage of the new Authorisation regime when compared to the old Licensing regime in the UK, is that all communications providers now only have to look to one set of general conditions to ensure they are complying with the law and there are no longer different licences containing different conditions. This move towards a single set of conditions for all service providers is consistent with the approach that has been adopted in Guernsey since the introduction of the legislation in 2001.

In the UK communications providers are also responsible for ascertaining which of the general conditions apply to them and their operations – they will not be issued with an individual licence which sets out their individual obligations. This is a key difference from the Guernsey regime where, currently, the OUR assesses applications and advises applicants of those conditions that apply to them. This is considered appropriate, given the current stage of development of the regime in Guernsey, which is barely two years old. In the UK, on the other hand, there is over 20 years experience in the market with that regulatory regime. There is also a large body of expertise in telecommunications law, and precedent in regulatory decision making to assist the service providers and operators.

## **6.2. Market Entry**

The perceived benefits of a separate licensing regime for ISP activities in the Bailiwick of Guernsey would appear to be that ease of market entry could be increased because:

- If a class license system were adopted, there would be no licence application fee, thus reducing the cost;
- The cost of regulating ISPs could be less than that of regulating full telecoms operators and therefore licence fees could potentially be less; and
- The administrative burden of applying for a licence would be removed and replaced by simple registration.

In balancing this however, the following must be considered:

- The current application fee for a licence in Guernsey is low at £2,500. As a business start up cost, this does not seem onerous, and if a business providing publicly available telecommunications services could not afford this level of up front fee, there may be questions as to the financial viability of the organisations, leading to concerns as to the continuity and permanence of services to customers;
- There is no reason to believe that the regulation of ISPs is any more or less onerous than the regulation of telecoms operators. In any event the existing licensing regime allows for licence fees linked to turnover, such that smaller businesses are not subject to large fees;
- In the absence of a licence application process, the onus would be on ISPs to register, but there would be an onus on the OUR to police the registration, monitor all ISPs in the Bailiwick, investigate their activities and ensure that they remained registered as long as they were providing internet access. This could increase the administrative role of OUR and potentially increase the costs of the office.

Overall the DG believes that the introduction of a separate licensing regime (either a class licence or an individual licensing regime) might not in fact reduce the barrier to entry into the telecommunications market in Guernsey. The increased complexity of administering a separate licensing regime could in fact potentially increase the cost of initial award of licensing over the current fee of £2,500. The DG is obligated to recover the costs of her office through fees from licensees, leading to the potential that licensees could in fact face increased application fees.

*Q.6.1 Do you agree that a separate regime could add complexity and cost to the application procedure?*

*Q.6.2 If not, please explain your reasons and demonstrate how costs could be reduced.*

### **6.3. Definition and Policing**

Aside from market entry, there are a number of issues to do with the definition of the activities to be licensed separately and the policing of the licence category that need to be considered.

In relation to the definition of what activities should be covered by a class licence, the DG is concerned that as described earlier, the convergence of technology means that there is no specific technical barrier to ISPs providing a full range of telecoms services, ranging from voice telephony over IP to multimedia, fax, data and internet access. Indeed, the provision of internet access facilitates the individual customer who may then be able to access services such as IP voice directly over the web.

The DG does not therefore consider it is feasible or advisable to distinguish a category of licensee based on a technical configuration as any such distinction would be meaningless.

It would appear to be necessary that any differential licensing regime would have to define ISPs who engage only in the provision of a specified range of services. For example it has been suggested that where an ISP undertakes not to provide voice telephony over IP but to restrict activities to pure internet access only, this could be a category of licensee that could be subject to a different set of licence conditions. This would require a self-policing role for ISPs who could be required to make a declaration of the types of services they would provide and notify the OUR if they went beyond that range of services.

The benefits of this approach would include:

- Ensuring that where an ISP did engage in activities that acted as a direct substitute for core telephony services, they would be subject to the same full licence conditions and obligations as other licensees, while allowing ease of market entry in the Internet access market only;
- The responsibility to remain within the specified range of services would lie with the ISP.

On the other hand:

- Unless self-policing were to be considered completely adequate, there would be an added burden and cost on OUR to investigate and examine the activities

of all ISPs in the Bailiwick to ensure compliance on a regular basis, thus increasing the overall cost of regulation on the economy;

- It would restrict ISPs to a specified range of services in a sector where change and development of new technology and services is rapid. ISPs could as a result find themselves unable to adapt quickly and offer new services to customers, potentially inhibiting innovation and creating an added administrative burden as each new service launch would have to be considered to determine whether or not it fell within the range of internet access services.

Overall the DG is concerned that the definition of specific services could be counter productive in that, in an attempt to reduce regulation and administration, it could in fact simply increase it.

However, in order to consider this further, respondents are invited to provide views on whether there should be such a service differentiation and if so how it should be defined and policed and what the benefits of a differentiation would be.

**Q.6.3** *Do you agree that a separate regime could add complexity and cost to the ongoing administration of the regime?*

**Q.6.4** *If not, please explain your reasons and demonstrate how costs could be reduced.*

## **6.4. Conclusion**

In conclusion, the DG is not convinced that a separate licensing regime for ISPs (or the provision of access to the internet) would be beneficial because;

- the barrier to market entry is already low and could in fact be increased by the introduction of complexity into the regime attendant on multiple licence categories and sets of conditions;
- the safeguarding of the public by ensuring the public service conditions are applicable to all service providers appears necessary;
- costs of defining and policing the distinction that might be applied would appear unduly burdensome and may result in higher charges to users with little visible benefit;
- imposing a constraint by defining the activities of a category of licensee could restrict innovation and the development of new services for customers as a further regulatory hurdle may need to be overcome to enable ISPs launch new services; and
- the introduction of a separate licensing regime goes against current EU best practice.

**Q.6.5** *Do you agree that a separate licensing regime for ISPS providing internet access would not be beneficial?*

**Q.6.6** *If not please explain why you disagree and describe the benefits you consider would accrue from a separate licensing regime?*

- Q.6.7** *If you believe there should be a separate licensing regime, please explain precisely what activities you consider should be subject to separate licensing and how these should be defined, technically, by service and legally.*
- Q.6.8** *If you believe there should be a separate licensing regime, please explain what conditions you consider should be included in the separate licence (please note you may wish to consider sections 7 and 8 of this paper before responding to this question).*

## **7. Rights, Entitlements and Obligations in Licences**

Under the current regime in Guernsey, there is one set of fixed licence conditions, one application procedure and a single fee for application for a licence. Each licensee receives an individual licence which contains all of the conditions in the fixed licence. However, not all of the conditions apply to each operator. Whether or not conditions apply is determined by the activities of the licensee and its position in the market, rather than by regulatory intervention.

As described in section 6.1, this regime provides the principle benefits of the new authorisation regime being adopted in Europe, while acknowledging the stage of development of the Guernsey market and the need to safeguard the public interest.

### **7.1. *Obligations in the Licence***

Thus a licensee must only comply with those conditions that are relevant to its business, i.e. if the licensee provides payphones as part of its business it must comply with the payphone condition. If an ISP were to hold a full licence, but did not provide payphones, then this condition would not apply. Similarly, if a licensee is found to have a dominant position in a relevant market, it must comply with specific conditions in relation to the separation of accounts. If the licensee does not have a dominant position, the condition does not apply. Certain conditions in the licence will apply to all licensees and these include conditions relating to;

- Public interest provisions;
- Consumer protection;
- Fair competition; and
- Conditions relating to frequency and numbering

### **7.2. *Interconnection and Access***

All licensees also have the same rights and entitlements which include the right to negotiate and establish interconnection with and access to the network of the incumbent dominant operator, Cable & Wireless Guernsey based on the Reference Offer (RO) published by that company. However, although all licensees may be entitled to enter negotiations, once again, the range of services and rates that can be obtained depends on the actual activity and technical development of the operator. For example, to obtain interconnection rates, the licensee must have the technical capability to establish C7 signalling interconnection with C&WG as specified in the RO. A licensee that cannot meet the requirements of the RO will not be able to gain the benefit of the RO rates.

Therefore the right to obtain RO terms is self policing by the market, thus reducing the administrative overhead of the OUR.

### **7.3. *Non-Discrimination***

Not all licensees will meet the technical requirements for RO rates and terms and conditions. However, all licensees are entitled to receive fair and non-discriminatory

terms and conditions from the incumbent dominant operator in that C&WG is required not to discriminate between its own downstream arm and other licensees in the services it sells.

Therefore licensees may request and may be granted services on the same terms and conditions as C&WG's own services. For example, ISPs should expect to pay precisely the same rate for Internet Backbone connectivity as C&WG's own tied ISP (cwgsy.net) pays.

#### **7.4. Conclusion**

This existing regime would appear to adequately provide that the rights, entitlements and obligations of the parties in the market are determined by their technical and financial capability and commitment in that only those operators who invest in the capability of interconnecting with the incumbent network will be able to obtain interconnection rates. Similarly only those meeting the technical requirements for access will be able to obtain access at the rates and terms and conditions in the RO.

On the other hand, the position of smaller operators or service providers in the market is protected in that the licence of the dominant incumbent requires non-discriminatory treatment of all service providers when compared to its own downstream arm. Thus, such licensees may receive service terms and conditions, including rates, that are different from those offered to retail customers, but that are also different to RO rates.

- Q 7.1 Do you agree that the rights and entitlements of operators (including ISPs) should be determined by their activities in the market rather than purely by regulatory intervention?***
- Q.7.2 If not please explain why and outline what rights and obligations you believe should be attached to specific categories of licences, including your reasons and the benefits you consider your preferred approach will bring.***

## 8. Proposed Adjustment of Existing Licensing Regime

The DG is conscious that the current licensing regime includes some conditions that apply to all licensees, including ISPs providing internet access. In the light of the conclusions reached earlier in this paper that a single licensing regime is appropriate, the DG believes is now considering whether, within that framework, there should be any adjustments to the range of conditions that apply and if so, why. This section addresses this question and goes on to consider how such adjustments could be implemented if they are considered beneficial.

### 8.1. Existing Licence Conditions

Appendix 2 to this paper sets out a brief summary of the conditions in the General Telecommunications Licence and the full text of the licence may be found in Document OUR 01/03 which is available on the OUR website ([www.regutil.gg](http://www.regutil.gg)).

The DG considers that some of these conditions may appear onerous to smaller ISPs or other players providing a small niche service only and is willing to consider mechanisms for removing any undue burden created by particular conditions. The specific conditions that might be considered in this light include:

- Condition 16 – monitoring and development plans;
- Condition 17.9 – minimum service levels;
- Condition 17.11 – six monthly reports on service levels;
- Condition 17.13 – establishment of User Councils; and
- Condition 22 – Cessation of Services.

The DG considers that all other conditions should remain applicable to all players in the market. However she would welcome views of interested parties on whether the proposed adjustments are considered appropriate and whether there are other conditions that interested respondents feel the DG should be prepared to consider exempting.

**Q 8.1** *Please consider the full list of conditions set out in Appendix 2 and indicate the conditions, if any, that the DG should consider dis-applying to ISPs or niche operators. Please explain your reasons in each case.*

However, in considering dis-applying certain conditions, the DG is mindful of the difficulties (discussed earlier in this paper) of defining a specific category of activities or licensees to which conditions should or should not apply. The DG considers therefore that it is incumbent on her, in accordance with the legislation, only to dis-apply conditions in response to fully justified requests for exemptions.

The DG proposes therefore that licensees, or applicants, may submit requests to have the specific licence conditions listed above dis-applied, providing their reasons and the effect that the granting of the request would have, including the benefits of dis-applying any conditions and how consumer interests will be protected in such cases.

This approach would allow the DG to consider each case on its merits and make a decision in the context of the benefits to the overall market.

**Q.8.3** *Do you agree that the dis-application of conditions should be considered on request only as described above?*

**Q.8.4** *If you disagree with the proposed approach, please explain why and suggest alternatives.*



## Annex 1: List of Questions

- Q.4.1 Do you agree that the above scenarios accurately describe the services provided by ISPs in Guernsey?*
- Q.4.2 If not, please explain your reasons and your alternative descriptions of ISP activities. Diagrammatic representation of your description would be very welcome.*
- Q.5.1 Do you agree that the provision of internet access should not be exempted from the requirement to hold a licence?*
- Q.5.2 If you do not agree please explain your reasons and illustrate how the exemption of the provision of internet access services would create benefits?*
- Q.5.3 If you consider that the provision of internet access should be exempt from licensing, please set out clearly your definition of what services should be exempt and whether (and if so which) any conditions should attach to the exemption.*
- Q.6.1 Do you agree that a separate regime could add complexity and cost to the application procedure?*
- Q.6.2 If not, please explain your reasons and demonstrate how costs could be reduced.*
- Q.6.3 Do you agree that a separate regime could add complexity and cost to the ongoing administration of the regime?*
- Q.6.4 If not, please explain your reasons and demonstrate how costs could be reduced.*
- Q.6.5 Do you agree that a separate licensing regime for ISPS providing internet access would not be beneficial?*
- Q.6.6 If not please explain why you disagree and describe the benefits you consider would accrue from a separate licensing regime?*
- Q.6.7 If you believe there should be a separate licensing regime, please explain precisely what activities you consider should be subject to separate licensing and how these should be defined, technically, by service and legally.*
- Q.6.8 If you believe there should be a separate licensing regime, please explain what conditions you consider should be included in the separate licence (please note you may wish to consider sections 7 and 8 of this paper before responding to this question).*
- Q.7.1 Do you agree that the rights and entitlements of operators (including ISPs) should be determined by their activities in the market rather than purely by regulatory intervention?*

- Q.7.2** *If not please explain why and outline what rights and obligations you believe should be attached to specific categories of licences, including your reasons and the benefits you consider your preferred approach will bring.*
- Q 8.1** *Please consider the full list of conditions set out in Appendix 2 and indicate the conditions, if any, that the DG should consider dis-applying to ISPs or niche operators. Please explain your reasons in each case.*
- Q.8.3** *Do you agree that the dis-application of conditions should be considered on request only as described above?*
- Q.8.4** *If you disagree with the proposed approach, please explain why and suggest alternatives.*

## Annex 2: Telecommunications Licence – Explanatory Note on Conditions

Condition No.	Heading	Purpose
<b>Part I</b>		
1	Definitions	Sets out the meaning attributed to certain terms used throughout the licence document.
2	Scope of the Licence	Establishes to whom the licence is issued, the nature of the licence, the requirements with regard to the control of the licensee and obligations with respect to any changes in control of the licensee that may take place.
3	Licence fee	Requires the licensee to pay a fee for the licence.
4	Provision of Information	This condition sets out some detail on how information required by the Director General may be obtained and obliges the licensee to comply with requests and provide all relevant information and assistance to obtain information. This is a crucial condition as the information requested will enable the Director General to make determinations in the best interest of users and the market as a whole.
5	Compliance	States that the licensee must comply with any and all directions issued by the Director General or as set down in law.
6	Modification	The licence should be viewed as a living document and changes may be required to be made to it over the term of the licence to take account of developments in the market. This condition provides for such modifications and the Telecommunications Law sets out in more specific detail the process to be followed in making modifications.
7	Enforcement and Revocation	This clause provides for the Director General to revoke the licence in accordance with the process and procedures set out in the Telecommunications Law, and for the licensee's obligations with respect to the provision of service to its customers at the time that any such revocation takes place.
8	Exceptions and Limitations	While it is assumed that the licensee will at all times make every endeavour to comply with its licence and any directions given to it by the Director General, if such

		compliance is prevented by force majeure, the licensee must inform the Director General, set out the impact on its duty to comply with the Licence and set out how it intends to rectify the situation. The Director General will consider such matters on a case by case basis.
9	Integrity of the Network	This condition provides for the Licensee to take steps necessary to ensure the integrity of the network. This is important so as to make sure that services to the public are not interrupted.
10	Interests of the Bailiwick	Requires the licensee to take all reasonable steps to prevent its network and services from being used to harm the interests of the Bailiwick.
11	Term and Renewal	Provides for the length of validity of the licence and for the licensee to seek renewal of the licence. The term of the licence is 15 years.
<b>Part II</b>		
12	USO	Requires the licensee to provide the USO specified by States Direction to the Director General and to comply with any direction from the Director General with regard to this condition as may be issued from time to time. It also deals with the establishment of a fund to meet the cost of providing the universal service should that be considered necessary.
13	Emergency Calls	Requires the licensee to provide emergency calls free of charge and to ensure the codes '112' and '999' are used exclusively for such calls.
14	Directory Information	Requires the licensee to provide its customers with access to any Directory Information Service offered by any licensed operator and co-operate in making information available to enable a Directory Information Service be provided. It also requires the licensee to ensure that it does not use information for any purpose other than the Directory Information Service, and comply with data protection legislation.
15	Public Payphones	Requires the licensee to maintain and operate payphones, sets out the services to be available from them and information to be made available to users. It also requires the licensee to give notice of its intention to withdraw a payphone from a specific location.
16	Service Levels	The licensee is required to provide a development plan setting out its targets for the

		ongoing development of the network and services, and a monitoring plan which measures achievement of those targets. This is designed to ensure the on-going development of the network and to ensure that the Bailiwick is provided with the highest level of infrastructure and service.
17	Consumer Protection	Requires the licensee to publish certain information with regard to its services and conditions, the manner in which it will deal with customer complaints, the provision of itemised billing and the publication of a consumers code for the resolution of disputes and in relation to the non-payment of bills and disconnections. It also requires licensees to prepare a draft statement on its minimum service levels for customers.
<b>Part III</b>		
18	Numbering	Requires the licensee to maintain its numbering allocation in an appropriate manner. It is further prohibited from charging customers for any number allocated unless authorised by the Director General.
19	Radio Frequency Spectrum	This condition is designed to ensure that the Licensee operates any radio based infrastructure including its mobile network and services in such a way as to avoid interference to other users and that its systems comply with the international standards with regard to non-ionising radiation emissions
20	Access to Land	Entitles licensee to the powers and rights set out in the Code as set out in Schedule 1 of the Telecommunications Law, subject to compliance with other relevant laws and codes within the Bailiwick, e.g. planning laws.
21	Access	Access to the network and services of the incumbent operator may be important to aid the introduction of competition into the telecoms sector. Due to constraints on land and to protect the environment, there may be circumstances where the only feasible means of accessing a customer for an operator may be by sharing or gaining access via another operator's property or network. This condition provides that the incumbent must, if so directed provide such access on equal terms and conditions to the access it provides itself.
22	Cessation of Services	Provides for the manner in which a licensee may cease service and the steps required of it in doing so. This is designed to ensure continuity of supply for the licensees

		customers.
<b>Part IV</b>		
23	Determination of Dominance	Under this condition the Director General may apply the conditions in Part IV of the Licence to any licensee that has been found to have a dominant position in a relevant market in accordance with Section 5 of the Telecoms Law.
24	Equal Access	The licensee, where requested by another operator, must grant 'equal access' – allowing the other operator access to its customers over the Licensees network using a selection of access methods as set out in the licence. This is designed to facilitate the introduction of competitive service providers whose services can be used by customers by dialling a short code or prefix.
25	Interconnection	This condition is critical. It provides for new entrants being able to piggy-back on the licensee's network to provide service to its customers. It enables faster roll-out of competition in advance of new entrants building such own network as they may require. In addition it is the means by which service competition will develop. The Licensee's charges for interconnection services must be non-discriminatory and cost-oriented.
26	Leased Circuits	A key building block in enabling new entrants to compete will be the ability to offer a full suite of services. The ability to buy wholesale leased lines at terms that are no less favourable than those offered by the Licensee to its own associated companies or business divisions will be an important element in meeting this aim. In addition, larger customers are significant users of leased circuits and this condition requires transparency and non-discrimination in relation to charges to such customers.
27	Separate Accounts	To aid the Director General in ensuring compliance with other conditions, the ability of the licensee to show that there is no below cost and/or cross subsidisation of any element of the business will be paramount. Keeping separate accounts for different activities is essential to calculate this.
28	Cross Subsidisation	This condition prohibits unfair cross-subsidisation and is intended to aid new entrants in assuring them that they are competing on a fair and equitable basis.

29	Undue Preference & Unfair Discrimination	This condition requires the Licensee to treat all classes of customers in a similar manner and provide them with similar terms and conditions.
30	Linked Sales	This condition prevents the Licensee from 'bundling' services or products so that a user or new entrant must purchase products or services which it does not require.
31	Price Regulated Services	This condition requires the Licensee to publish details of new services or prices, discounts on services or special offers and submit information relating to the proposal to the Director General. The purpose of this is to ensure that any such changes/introductions are compliant with the requirement to be transparent, non-discriminatory and cost-justified.
<b>Part V</b>		
32	Fair Competition	Requires all licensees to behave in a fair way and not engage in anti-competitive practices.
33	Misuse of data	Requires the licensee to handle information received in a manner that does not benefit it or any associated companies or in a manner that anti-competitive towards other operators.